

**TYPE 1 CROSS RECESS
82° FLAT HEAD
TRILOBE 48-2 T.F.S.**

XXXXPPZ
APRIL, 2014
REV 00
PAGE 1 of 1

Nominal Screw Length	Tolerance On Screw Length
Up To & Including 3/4"	± .030
Over 3/4"	± .050

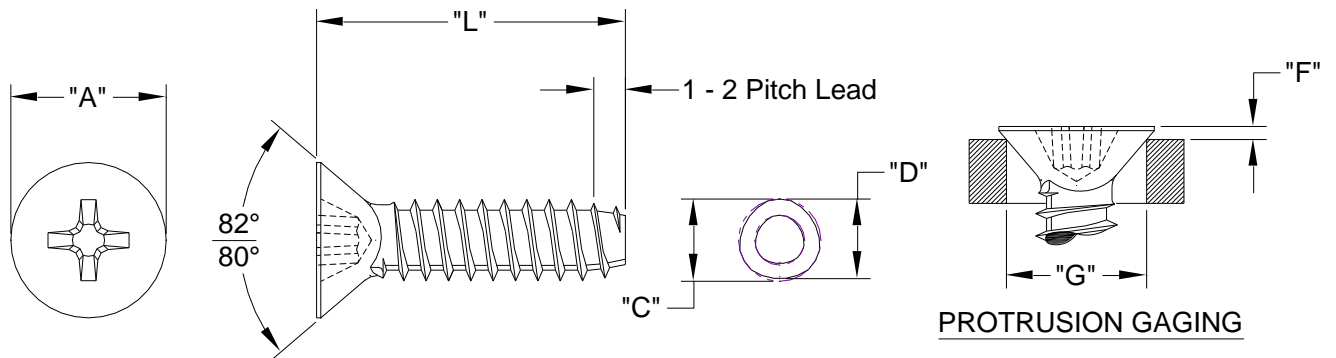

Nominal Screw Size	"C"		"D"		For These Lengths & Shorter Are Undercut	"A"		Driver Size	Recess Penetration Gaging Depth		"G" Gaging Diameter	"F" Protrusion Height	
	Circumscribing Circle		Major Diameter			Head Diameter			Max.	Min.		Max.	Min.
	Max.	Min.	Max.	Min.		Max.	Min.						
#2-28	0.092	0.086	0.089	0.083	3/16	0.162	0.144	1	0.056	0.04	0.124	0.029	0.017
#4-20	0.127	0.121	0.123	0.117	1/4	0.212	0.191	1	0.082	0.066	0.172	0.032	0.019
#6-19	0.147	0.141	0.143	0.137	5/16	0.262	0.238	2	0.095	0.072	0.220	0.036	0.021
#8-16	0.185	0.179	0.179	0.173	7/16	0.312	0.285	2	0.11	0.087	0.267	0.039	0.023
#10-14	0.212	0.206	0.208	0.202	1/2	0.362	0.333	2	0.125	0.102	0.313	0.042	0.025
1/4-10	0.276	0.270	0.268	0.262	5/8	0.477	0.442	3	0.154	0.131	0.424	0.050	0.029

Head Standard: ASME B18.6.3 Material: Steel Case Hardened Surface Hardness: Rc45 Min Finish: Commercial Zinc, Bake, ROHS Compliant Clear Chromate Per ASTM F1941 Code Fe/Zn 3A & Wax	COMMON USES: Plastics Less Than 800,000 psi Flexural Modulus
--	---