

SLOTTED PAN HEAD TYPE "F" TCS

XXXXSPFZ
APRIL, 2014
REV 00
PAGE 1 of 1

Nominal Screw Length	Tolerance On Screw Length
Up To & Including 3/4"	-0.03
Over 3/4" to 1-1/2" Inclusive	-0.05
Over 1-1/2"	-0.06

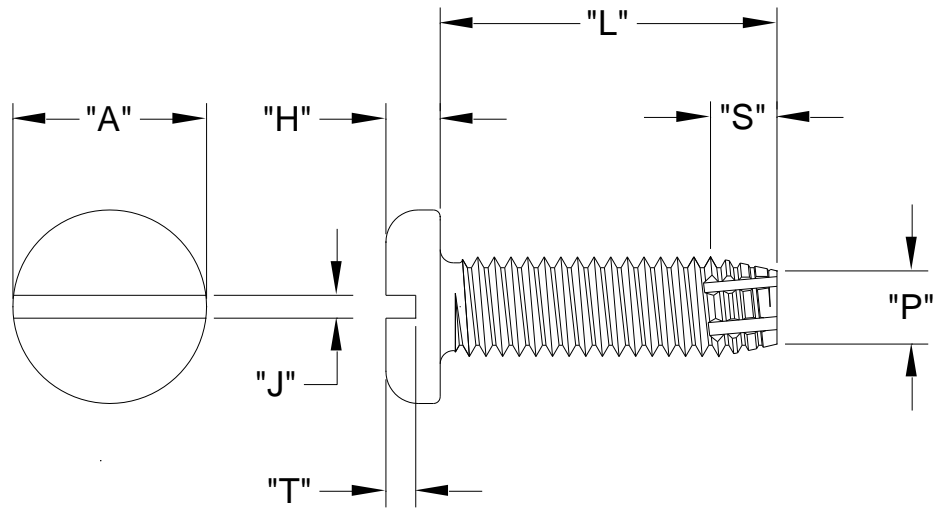

Nominal Screw Size	Basic Screw Size	"D"		"p"		"S"				Determinant For Point Taper Length	"A"		"H"		"J"		"T"	
		Major Diameter		Point Diameter		Point Taper Length					Head Diameter		Head Height		Slot Width		Slot Depth	
		Max.	Min.	Max.	Min.	Max.	Min.	Max.	Min.		Max.	Min.	Max.	Min.	Max.	Min.	Max.	Min.
#4 - 40	0.112	0.1120	0.1061	0.087	0.078	0.088	0.062	0.112	0.088	7/32	0.219	0.205	0.068	0.058	0.039	0.031	0.040	0.030
#6 - 32	0.138	0.1380	0.1312	0.107	0.096	0.109	0.078	0.141	0.109	1/4	0.270	0.256	0.082	0.072	0.048	0.039	0.050	0.037
#8 - 32	0.164	0.1640	0.1571	0.132	0.122	0.109	0.078	0.141	0.109	1/4	0.322	0.306	0.096	0.085	0.054	0.045	0.058	0.045
#10 - 24	0.190	0.1900	0.1818	0.148	0.135	0.146	0.104	0.188	0.146	11/32	0.373	0.357	0.110	0.099	0.060	0.050	0.068	0.053
#10 - 32		0.1900	0.1831	0.158	0.148	0.109	0.078	0.141	0.109	1/4								
1/4 - 20	0.250	0.2500	0.2408	0.200	0.184	0.175	0.125	0.225	0.175	13/32	0.492	0.473	0.144	0.130	0.075	0.064	0.087	0.070

Standard: ASME B18.6.3
 Material: Carbon Steel,
 Heat Treat: Case Hardened Rc45 Min.
 Finish: Commercial Zinc, Bake & ROHS Compliant Clear Chromate
 Per ASTM F1941 Code Fe/Zn 3A

Common Uses:
 Most Common Head Style; Higher Head Height For Increased Strength; Used In sheet metal ≥60% of screw dia.; Painted extruded sheet metal; Paint clearing in tapped holes.